

Burning Petals

By Emily Siri Brown

Subcategory: Industrial Design

Burning Petals is a design I created in response to the growing world and strengthening negative effects of fast fashion. It is designed to last a lifetime for a user and not be disregarded as a fad item.

DESIGN BRIEF:

Design one functional textile garment and an accessory out of three different cotton fabric types

- Explain the lifecycle of the textile item from concept to disposal/renewable (circular process)
- Ensure the design uses minimum waste when cutting the fabric
- How will the excess fabrics be used? (e.g. as another product/accessory)
- The design should be aligned to any chosen theme



Music has been used as a form of expression for tens of thousands of years. I was inspired by the sounds of the punk-rock genre, especially its themes of protest, both against the government and personal aspects such as family or self-identity. Protest fits with a 100% cotton garment due to the large amount of recent environmental protests and climate strikes. Cotton is incredibly environmentally friendly because it is sustainable, renewable and biodegradable (Cotton Campus, n.d.). Additionally, the Australian cotton industry is the “most water efficient cotton industry in the world” (Cotton Australia, 2020).

My design’s main garment is a blazer. Blazers are classic wardrobe items and can be dressed up or down. Blazers are versatile, remaining in one’s closet for a long period of time, strengthening the concept of slow fashion and minimising waste. Protest is present through unconventional aspects of the garment: side cut-outs, cropped length, a stand-up collar and half-sleeves. I chose a black, white and dark pink colour palette with an embroidered rose-on-fire motif. The motif is symbolic of a burning world and the ruining of nature due to harmful textile practises such as fast fashion, the production of manmade synthetic fibres and freshwater contamination from dye by-products. The matching military cap represents wanting peace between humans and the environment.

Fabric made from recycled cotton is even more sustainable than new cotton as it reduces energy and water use while preventing clothing from going to land fill (Raturier, 2019). The prevention of waste production is significant as over 500 000 tonnes of clothing waste is sent to landfill per year in Australia (The Conversation, 2019). However, mechanical process used to recycle cotton usually produce lower quality fabrics as the material is shredded to create a raw cotton fibre. Therefore, recycled cotton is often used in low grade products including mop heads, stuffing and, commonly, paper. Additionally, contamination by other fibres in resulting cotton products is quite high with recycled cotton fibres usually blending with other fibres to improve strength and durability and the finished fabric is often more expensive than new cotton (Cotton Works, n.d.).

The main fabric of my design will be a black pinwale (18-wale) corduroy. Corduroy is warm, soft, durable and breathable, meaning the garments will be able to be worn from Autumn to Spring for many years (Encyclopedia Britannica, 2008). Additionally, corduroy is a versatile fabric, working in both professional and casual settings, increasing the amount it can be worn. The extra weft yarns, later cut to form the vertical pile, can be made from entirely recycled cotton as they do not need to be strong with long fibres.

The hat and blazer will be lined with a plain black voile. Voile is lightweight, breathable, stiff but flexible, non-stretch, soft to the touch and has a tight weave, making it reasonably durable (Tissura, n.d.). Unfortunately, using recycled fibres in the voile will not produce a high enough quality fabric. However, Australian cotton would be used, which is fair trade and sustainable. Finally, the dark pink and white accents will be made from cotton drill -- a twill weave with diagonal lines and a third more yarns than a plain weave, making it stronger and more durable than plain weave fabrics. The weave ensures that the decorative aspects will drape nicely and will not be susceptible to wear (Garg, 2016). In addition to the colour, the drill will also bring a different texture to the garment.

Cutting the pattern pieces will produce a lot of waste – especially since corduroy is directional -- however, since the hat will be made from the same materials, scraps from the blazer will be used on the hat and any other waste will be moved to a recycling plant. Furthermore, all resources used will be as sustainable as possible (recycled, water efficient, the use of deadstock, etc). My design will be labelled with the Australian Cotton Mark (95% or more Australian cotton), which reflects the highest quality fibres. Due to these practices and the high potential for use, my design is incredibly sustainable, resulting in a positive environmental impact.

- Australian Cotton, n.d., *Branding Your Products With the Australian Cotton Marks*, viewed 26 August 2020, <https://australiancotton.com.au/assets/downloads/Australian_Cotton_Marks_-_FLYER_EMAIL.pdf>
- Cotton Australia, n.d., *Industry Overview*, viewed 26 August 2020, <<https://cottonaustralia.com.au/industry-overview>>
- Cotton Campus, n.d., *Cotton Sustainability: Frequently Asked Questions*, viewed 26 August 2020, <<https://www.cottoncampus.org/cotton-environmentally-friendly-sustainability/#:~:text=Cotton%20is%20sustainable%2C%20renewable%2C%20and,they%20come%20from%20nonrenewable%20resources.&text=The%20average%20acre%20in%20the%20U.S.%20produces%20about%20800%20pounds%20of%20cotton.>>>
- Cotton Works, n.d., *Recycled Cotton*, viewed 26 August 2020, <<https://www.cottonworks.com/topics/sustainability/cotton-sustainability/recycled-cotton/#>>
- Daniels, A., 2013, *What Every Professional Woman Needs – The Perfect Blazer*, viewed 26 August 2020, <<https://www.forbes.com/sites/forbesstylefile/2013/06/03/what-every-professional-woman-needs-the-perfect-blazer/#279b91477808>>
- Editors of Encyclopedia Britannica, 2008, *Corduroy*, viewed 26 August 2020, <<https://www.britannica.com/topic/corduroy-fabric>>
- FAIRTRADE International, n.d., *The Fairtrade Marks*, viewed 26 August 2020, <<https://info.fairtrade.net/what/the-fairtrade-marks>>
- Garg, S., 2016, *All about drill fabric from Cotton drill fabric manufacturers*, viewed 26 August 2020, <<https://medium.com/@srg.weaving/all-about-drill-fabric-from-cotton-drill-fabric-manufacturers-20242c7ea3e5>>
- Raturier, S., 2019, *What Are the Most Sustainable Fabrics?*, viewed 26 August 2020, <<https://goodonyou.eco/most-sustainable-fabrics/>>
- The Conversation, 2019, *Circular fashion: turning old clothes into everything from new cotton to fake knees*, viewed 26 August 2020, <<https://theconversation.com/circular-fashion-turning-old-clothes-into-everything-from-new-cotton-to-fake-knees-115636>>
- The Fabric of Our Lives, (n.d.) *Cotton Fabrics*, viewed 26 August 2020, <<https://thefabricofourlives.com/cotton-fabrics>>
- Tissura, n.d., *Voile Fabric Knowledge*, viewed 26 August 2020, <<https://tissura.com/articles/voile-fabrics>>
- Wool4School, 2020, *Student booklet*, viewed 26 August 2020, <<https://www.wool4school.com/globalassets/wool4school/about/students/w4s-au-student-booklet-2020.pdf/>>

Burning Petals

Emily Siri Brown
Protest

Size	16
Bust	97 cm
Waist	76 cm
Back Waist Length	42.5 cm
Head Circumference	57 cm

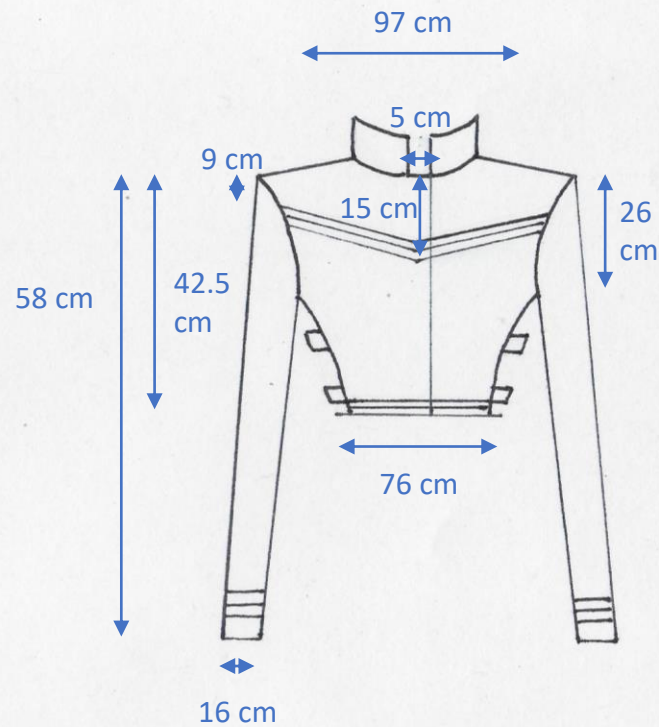

Front

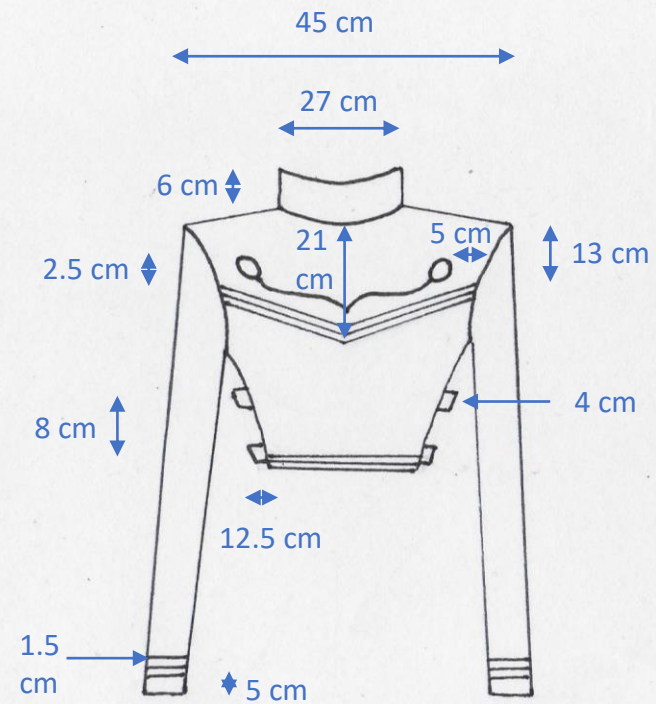

Back

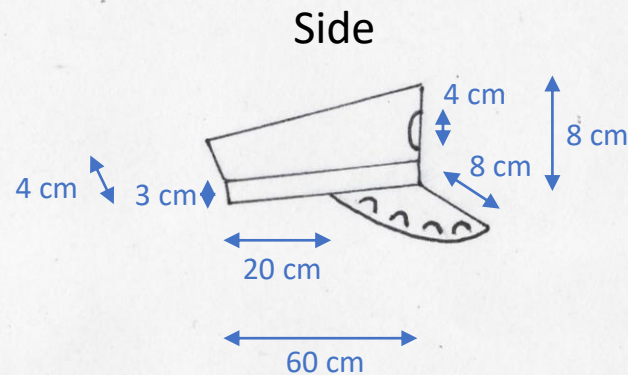

Side

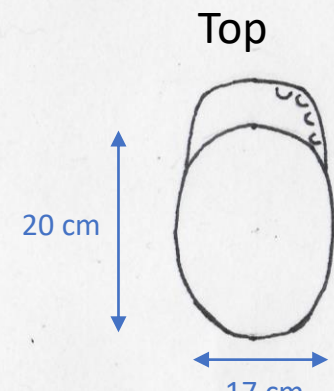

Top

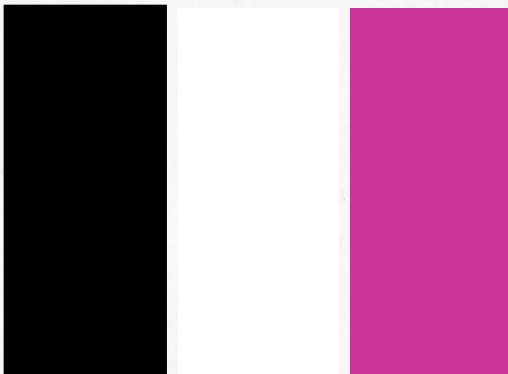

Burning Petals

Emily Siri Brown
Protest

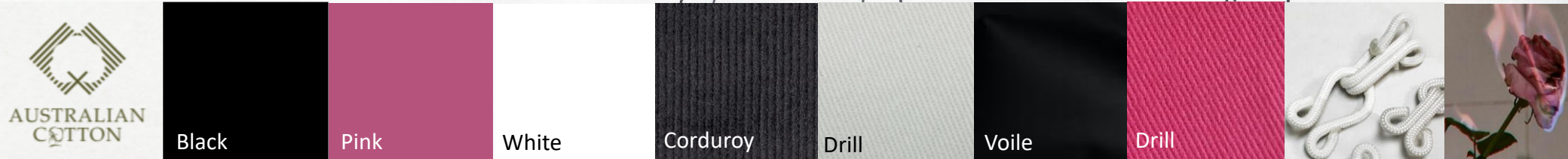
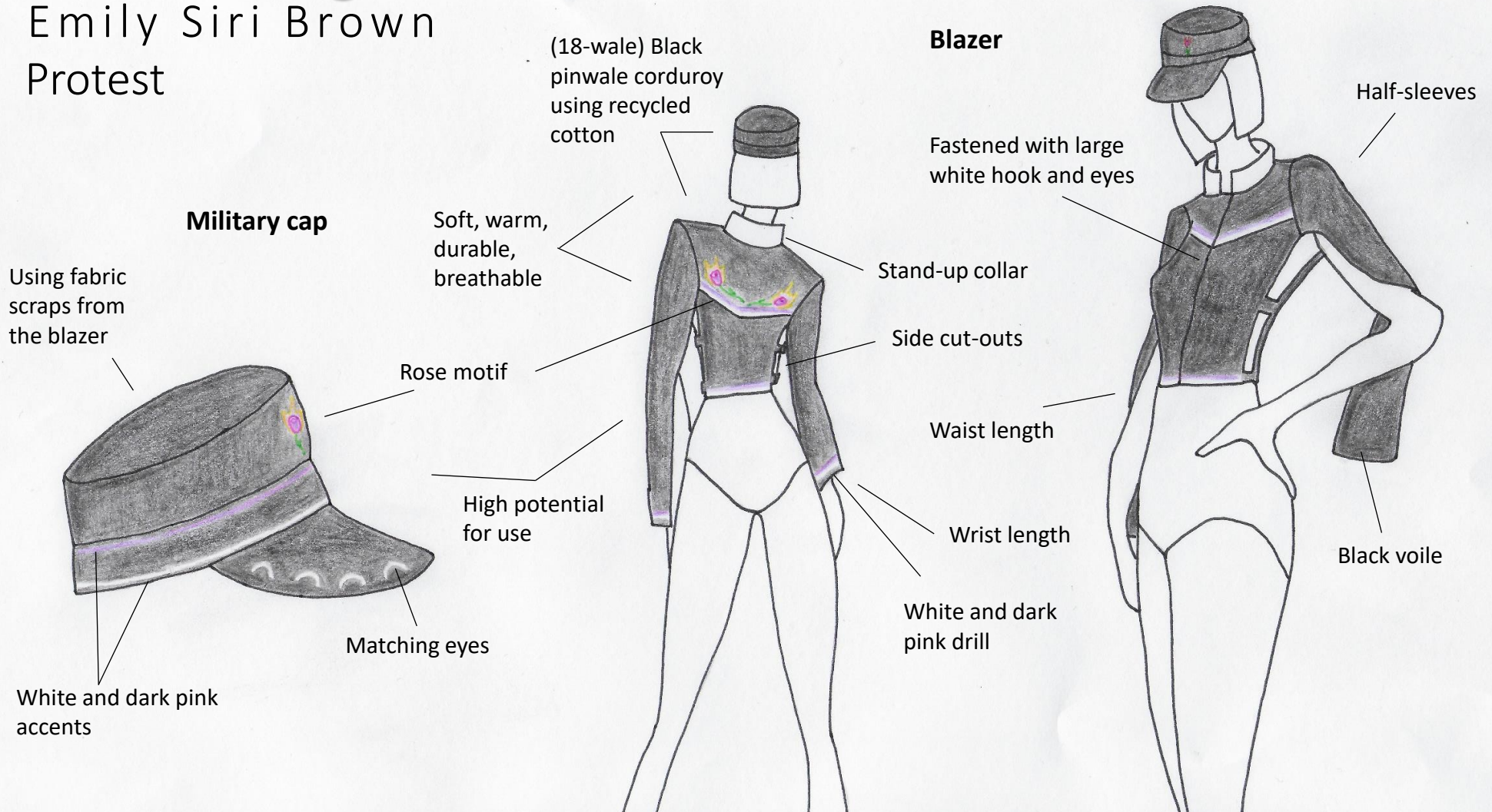

Burning

Petals

Emily Siri Brown

test

